

Scientific Herald of Uzhhorod University

Series "Physics"

Journal homepage: <https://physics.uz.ua/en>

Issue 54, 18–26

Received: 26.07.2023. Revised: 31.10.2023. Accepted: 18.12.2023

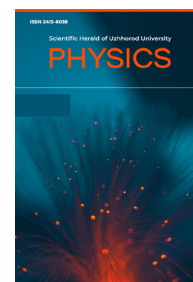

UDC 621.54

PACS 73.40. Lq, 81.05. Hd

DOI: 10.54919/physics/54.2023.18

Influence of the phthalimide on the process of electrical aging of the high-pressure polyethylene

Shucayat Aman Zeynalov

PhD in Physics, Associate Professor

Azerbaijan Technical University

AZ 1073, 25 H. Javid Ave., Baku, Azerbaijan

<https://orcid.org/0000-0002-0040-6057>

Farhad Shamil Kerimov

PhD in Physics, Associate Professor

Azerbaijan Technical University

AZ 1073, 25 H. Javid Ave., Baku, Azerbaijan

<https://orcid.org/0009-0005-8006-5481>

Sevinj Ittifaq Safarova*

PhD in Physics, Associate Professor

Azerbaijan Technical University

AZ 1073, 25 H. Javid Ave., Baku, Azerbaijan

<https://orcid.org/0009-0003-5928-1177>

Sayyara Heydar Sadygova

PhD in Physics, Associate Professor

Azerbaijan Technical University

AZ 1073, 25 H. Javid Ave., Baku, Azerbaijan

<https://orcid.org/0009-0003-0492-4825>

Tahir Pasha Musaev

PhD in Physics, Associate Professor

Azerbaijan Technical University

AZ 1073, 25 H. Javid Ave., Baku, Azerbaijan

<https://orcid.org/0009-0001-6719-874X>

Abstract

Relevance. The use of polyolefins without additional processing methods, namely, the increase in their electrophysical characteristics, is an actual modern requirement. For this, it is necessary to use the mechanism of ionization ageing where the role of the modifying additive must be elucidated by the method of infrared spectroscopy in high-pressure polyethylene.

Suggested Citation:

Zeynalov SA, Kerimov FS, Safarova SI, Sadygova SH, Musaev TP. Influence of the phthalimide on the process of electrical aging of the high-pressure polyethylene. *Sci Herald Uzhhorod Univ Ser Phys.* 2023;(54):18–26. DOI: 10.54919/physics/54.2023.18

*Corresponding author



Copyright © The Author(s). This is an open access article distributed under the terms of the Creative Commons Attribution License 4.0 (<https://creativecommons.org/licenses/by/4.0/>)

Purpose. The research aims to study the effect of low molecular weight organic additives of phthalimide on molecular structural changes in polymers that occur under external action.

Methodology. The impact of electrical discharges on polymer dielectrics was carried out in a test cell of an asymmetric type. Tested polymer film before and after pre-stretching was tightly stretched onto this plate following the research procedure. To create an air gap of constant thickness between the top electrode and the polymer film, 1.5 mm thick glass spacers were placed along the edges.

Results. The electrical strength (lifetime) of high-pressure polyethylene (LDPE) and its optimal modification before and after electrical ageing was investigated. Following experimental data, at the content of 0.05 wt. % LDPE its electrical strength reaches a maximum value compared to both the original LDPE and LDPE at other additive contents. The introduction of 0.05 wt.% phthalimide into high-pressure polyethylene contributes to a noticeable decrease in the intensity of the formation of C = O groups, which is the measure of the oxidative degradation of polymer chains.

Conclusions. The optimal composition of the phthalimide was determined and their electrophysical properties were studied. It was found that composites with additions of 0.05 wt.% phthalimide significantly improve the electrophysical properties of LDPE.

Keywords: infrared spectrum; lifetime; polymer chains; electrophysical properties; electrical durability

Introduction

The most important advantages of polymeric materials, which include first of all a low specific weight, are the ability to be processed in a product of complex configurations using productive and accessible techniques, the possibility of imparting to them a complex of valuable technical properties (chemical resistance, strength, high electrical insulating characteristics, etc.), as well as the availability of a wide raw material base.

Furthermore, a good combination of physical and mechanical properties of polymeric materials makes it possible to use them more and more widely as electrical insulation and dielectrics in the cable industry, capacitor building, and in the production of electrical machines and appliances.

The use of these materials has revealed some common disadvantages of this type of material. E.M. Godzhaev *et al.* [1] noted that one of the most significant among them is the tendency of polymers to so-called “ageing”, which is expressed by the deterioration of properties during storage, processing, and operation, that occurs in strong electric fields by the deterioration of the electrical and mechanical properties of polymer insulation mainly due to ionization processes developing in air inclusions and pores inside the insulation. According to A.R. Sadigova *et al.* [2] a significant breakthrough is taking place in connection with the new possibilities of nanotechnologies, namely, the possibility of regulating the supramolecular structure of polymer composites at the nano level. Nanofilled systems are increasingly being studied to improve the physical and mechanical characteristics of polymers.

A.A. Khadiyeva *et al.* [3] aimed to develop new polymer compositions with increased electrical strength,

which prevent the deterioration of the physical and mechanical properties of polymeric materials and compositions based on them and suppress destructive processes under the separate and simultaneous action of various factors, for example, a strong electric field and discharges, various irradiations of temperature, mechanical loads, etc., as well as the effect of the organic additive on the supramolecular structure of the polymer composition

Studies [4; 5] noted that it is to obtain a three-dimensional image of the surface, a scanning electron microscope is employed, which uses electrons scattered or emitted by the surface of the sample. The sample, in this case, is fixed, dried, and coated with a thin film of heavy metal, and then scanned with a narrow beam of electrons. At the same time, the number of electrons scattered when the surface is irradiated is estimated. J. Almond *et al.* [6] claimed the use of SPM for the study of objects of intensity control of the second beam, moving synchronously with the first and forming an image on the monitor screen. The resolution of the method is about 10 μm . The thickness of the samples studied by this method is determined by the penetrating power of the electrons or their energy.

Scanning probe microscopy is one of the most powerful modern methods for studying the morphology and local properties of a solid body with high spatial resolution. Scanning probe microscopy has evolved from an exotic technique, available only to a limited number of research groups, to a widespread and successfully used tool for studying surface properties. According to D. Nečas [7], almost no research in the field of surface physics and thin-film technologies is complete without the use of scanning probe

microscopy methods. The development of scanning probe microscopy also served as the basis for the development of new methods of nanotechnology – technologies for creating structures with nanometer scales. Currently, probe microscopy is a rapidly developing field of technology and applied scientific research.

The research aims to develop new polymer compositions with increased electrical strength and resistance to electrical ageing, as well as to identify the effect of additives on the supramolecular structure of the polymer composition.

Materials and Methods

High-pressure performance polyethylene (LDPE) grade 10803-020 (Azerbaijan) was chosen as the object of study and the organic compound phthalimide (chemical formula $C_6H_4(CO)_2NH$) was used as an additive. The size of the additive particles was less than $50 \mu m$. Additives in the amount of 0.01-0.1 wt.% were introduced into the LDPE by mechanical mixing. Research samples were made as films with a thickness of 50–60 μm by pressing on a hydraulic press. Technological parameters of pressing are: temperature – $150^\circ C$,

pressure – 15 MPa, pre-heating time – 10 min, holding time under pressure – 5 min, cooling time – 2 min. Measurement of the electrical durability (lifetime) of the tested samples was carried out on the breaking apparatus, where a special cell was developed, consisting of two steel disk electrodes with diameters of 30 and 10 mm, respectively [6-8].

The impact of electrical discharges on polymer dielectrics was carried out in a test cell of an asymmetric type. The studied polymer film was placed between two metal electrodes. A smooth stainless-steel plate (nickel-plated on one side) with dimensions 180×130 mm was taken as the lower grounded electrode. Following the procedure, the tested polymer film before and after pre-stretching was tightly stretched onto this plate. To create an air gap of constant thickness between the top electrode and the polymer film, 1.5 mm thick glass spacers were placed along the edges. A schematic diagram of the described cell is shown in Figure 1. A high-power frequency voltage (HV) was applied to the cell electrodes from an AII-70 apparatus (Azerbaijan). Research was carried out at Azerbaijan Technical University.

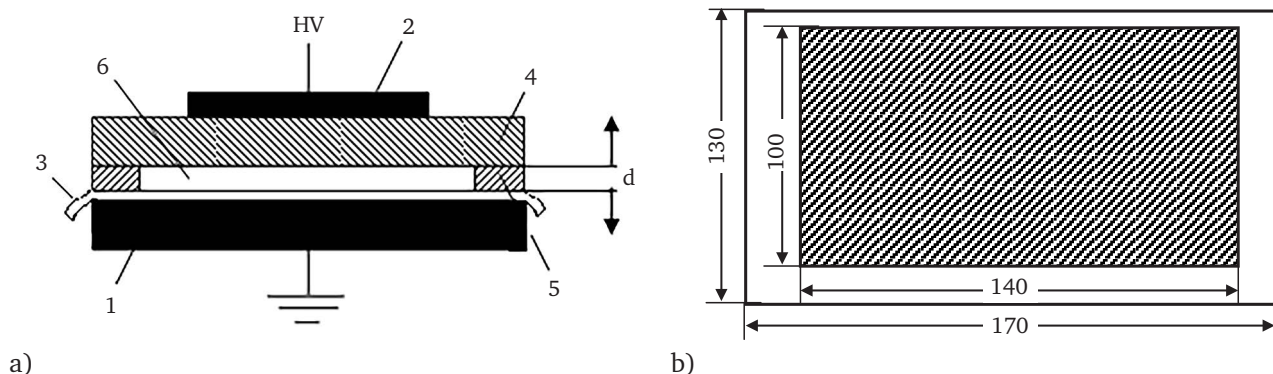

Figure 1. Test cell with an air gap

Note: 1 – metal Ground electrode, 2 – metallized glass plate, 3 – metal coating, 4 – glass spacers (b), 5 – polymer film HV (a)

Source: compiled by the authors

The IR-spectra (IR – infrared) of the samples were recorded using UR-20 (UR – ultra red, Azerbaijan) spectrophotometer in the range of $(700-3600 \text{ cm}^{-1})$ of both initial LDPE films and its optimal modifications before and after electrical ageing. When studying the changes in the IR spectra of the samples with the time of their ageing, a special frame was used, which was used to periodically record the spectrum of the same part of the sample during the entire test period. The UR-20 operating mode was characterized by the following parameters: scanning speed – $\sim 400 \text{ cm}^{-1}/\text{min}$, fricative program – “7.5”, gain – “7-8”, steam speed – $4 \text{ min}/100\%$. The spectra were compared for films of equal thickness (the IR spectrum was carried out at the Institute of Physics of the Academy of Sciences of the Republic of Azerbaijan).

Results and Discussion

Research in the field of creating materials with special and practically important electrophysical properties based on polymer structures saturated with capture centres with different values of activation energy, in which electrons are stabilized, is highly relevant. Depending on the nature of the filler, the shape, size, and nature of the distribution of particles in the matrix, as well as on the interaction between the constituent components, polymer composites with different electrophysical, spectral-luminescent and other properties are obtained.

The introduction of various fillers leads to the expansion of the possibilities of the practical application of the composite material since the nature of the aggregation of filler particles, crystallization

conditions and several other factors change the morphology of the polymer matrix, and as a result, the composite materials obtained on their basis acquire unique properties. Figure 2 shows the dependence of the short-term electric strength E_s of low-density polyethylene on the amount of phthalimide. With

an increased percentage by weight of phthalimide, its electrical strength increases and reaches its maximum value at 0.05 wt.% of phthalimide. With a further increase in the amount of phthalimide to 0.1 wt.%, a sharp decrease in the electrical strength of the material is observed.

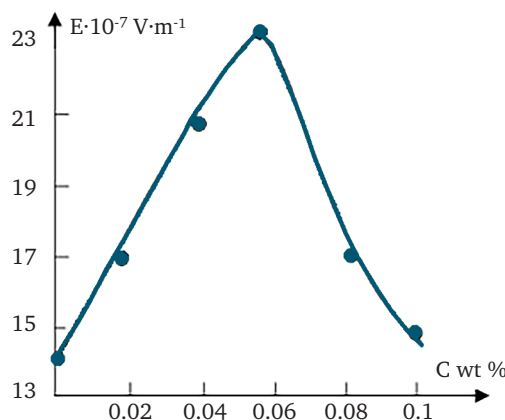

Figure 2. The electrical strength of the LDPE film depends on the amount of phthalimide

Source: compiled by the authors

The observed increase in electrical strength of polyethylene films at the optimum content (0.05 wt.% FI) is associated with structural changes occurring after the introduction of additives into them [9; 10]. This is also confirmed by the study of the effect of adding a small amount of phthalimide on the time

dependence of the electrical strength of the LDPE film before and after electrical ageing (Fig. 3). Figure 3 shows a plot of the logarithm of the lifetime of the initial LDPE modified by phthalimide additives (LDPE + 0.05 wt.% FI) on the electric field strength before and after electrical ageing.

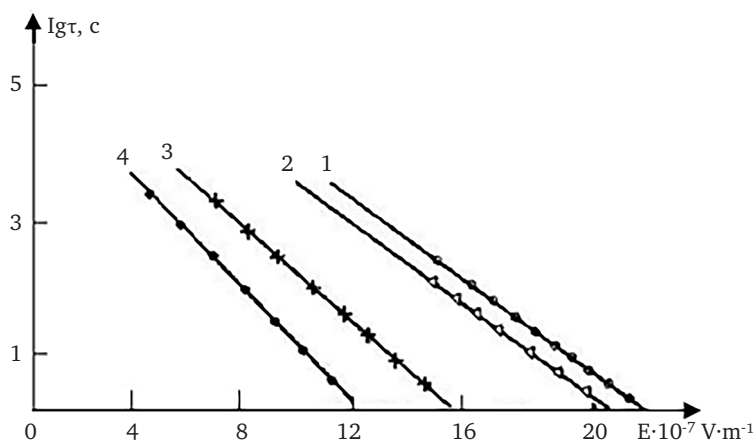

Figure 3. Dependence of the electrical durability of the initial and modified (LDPE + 0.05 wt% phthalimide) LDPE films before (1, 3 respectively) and after electrical ageing in the air at $U = 7 \text{ kV}$, $t = 5 \text{ hours}$ (2, 4) on the electric field strength

Source: compiled by the authors

As can be seen from Figure 3, in all cases at a given temperature with an increase in the electric field strength, the logarithm of the lifetime decreases linearly, i.e., the well-known relation $\tau = B \exp(-\beta E)$ is true, where B and β are parameters depending on the composition of the test material and the temperature of the electrical durability [11-13]. Figure 3

shows the introduction of 0.05 wt% phthalimide into LDPE increasing the electrical strength from $14 \cdot 10^{-7} \text{ V}\cdot\text{m}^{-1}$ (line 3) to $22.5 \cdot 10^{-7} \text{ V}\cdot\text{m}^{-1}$ (line 1). At the same time, the lifetime of the modified LDPE film is relatively stable during electrical ageing under the action of electrical discharges. Indeed, after the electric discharge, the electric strength of

LDPE + 0.05 wt.% phthalimide film decreases slightly, i.e. from $22.5 \cdot 10^{-7} \text{ V}\cdot\text{m}^{-1}$ (line 1) to $21 \cdot 10^{-7} \text{ V}\cdot\text{m}^{-1}$ (line 2), while LDPE film without additive has a significant drop in strength from $14 \cdot 10^{-7} \text{ V}\cdot\text{m}^{-1}$ (line 3) to $8 \cdot 10^{-7} \text{ V}\cdot\text{m}^{-1}$ (line 4).

Sh. Zeynalov *et al.* [14] studied the effect of phthalimide additives in the optimal amount on the change in electrical strength under ultraviolet irradiation in air. Research results have shown that the introduction of phthalimide additives into low-density polyethylene in an optimal amount leads to a significant increase in its electrical strength and, secondly, the detected

increased properties of the modified LDPE remain unchanged after UV irradiation with a duration of 15 hours in air. The mechanism of growth of the electrical strength of polyethylene with the introduction of micro additives of phthalimide up to 0.05 wt %, as well as an increase in the resistance of polyethylene to electrical ageing can be explained based on the change in the intensity of some bands, and the appearance of background on the IR spectra. Figures 4 and 5 present the experimental results obtained from the absorption bands of the IR spectra for LDPE films and their optimal modifications.

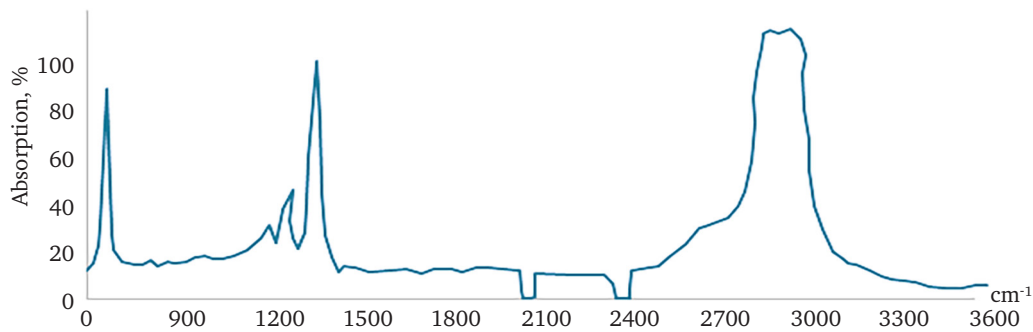

Figure 4. IR spectra of LDPE films before electrical aging

Source: compiled by the authors

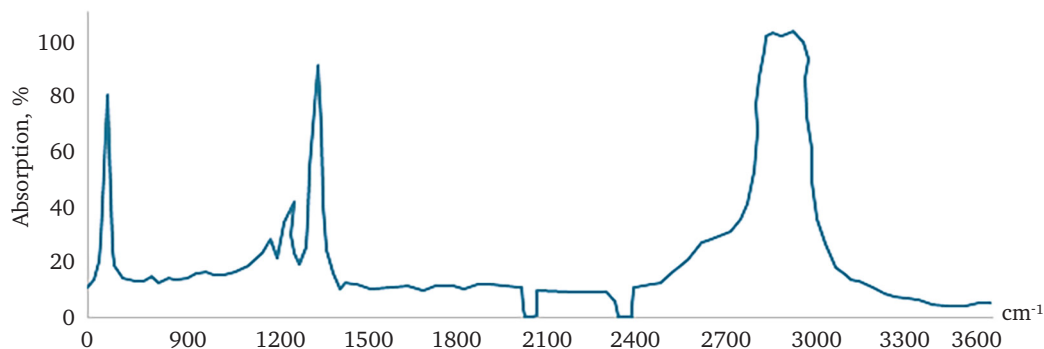

Figure 5. IR spectra of the LDPE film with the optimal amount of phthalimide before electrical ageing

Source: compiled by the authors

A comparison of these spectra shows that in all the cases considered, the introduction of the modifier used in the indicated amount into LDPE does not contribute to the appearance of new absorption bands, i.e., practically does not change the shape of their IR spectra. This suggests that these modifiers in the proposed amount are technologically compatible with LDPE. In other words, they mainly affect the physical structure of LDPE.

Indeed, the achievement of the effect of adding small amounts is mainly due to interstructural plastification. A.A. Garibli *et al.* [15] examined the interaction between components in the composite material consisting of nanosilicon and polypropylene. This investigation utilizes Fourier Transform Infrared Spectroscopy (FTIR) and X-ray diffraction (XRD) methods

to analyse and characterize the composite. XRD was used to utilize and investigate the crystalline structure and phase composition of the composite. XRD is a powerful technique for determining the arrangement of atoms within the material and identifying any crystallographic changes that may occur due to the interaction between nanosilicon and polypropylene. S.H. Kim *et al.* [16] addressed the decomposition of low-density polyethylene and the energy output achieved through the utilization of dielectric barrier discharge under varying electrical circumstances. Z. Qiao *et al.* [17] and B.C. Smith [18] aimed to gain insights into the long-term performance of polyethylene insulation under thermal ageing conditions, which is crucial for the reliability of track cable systems. An

established understanding of the space charge behaviour in aged polyethylene insulation is essential for improving the maintenance and lifespan of track cables, ensuring the safe and efficient operation of rail transportation networks.

To establish the contribution of the phthalimide additive to the process of electrical ageing of the LDPE film, similar structural studies of the samples were carried out after their electrical ageing. These results are shown in Figures 6 and 7.

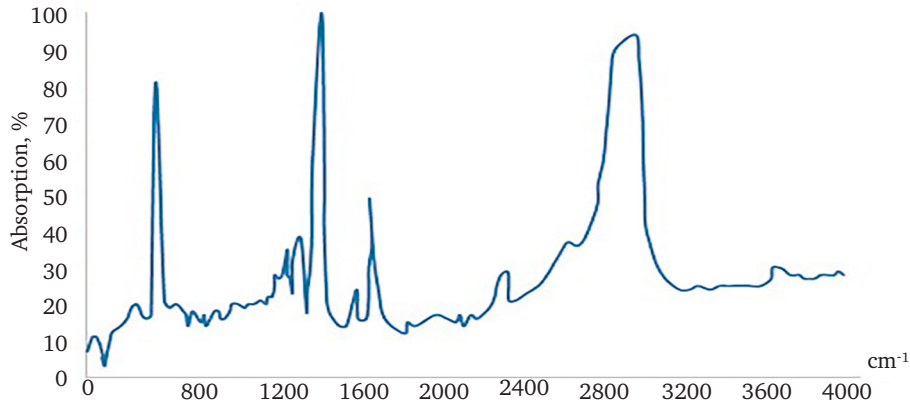

Figure 6. Change in the IR spectra of the LDPE film after electrical ageing under the action of discharges in air

Note: $U = 7 \text{ kV}$, $t = 5 \text{ hours}$

Source: compiled by the authors

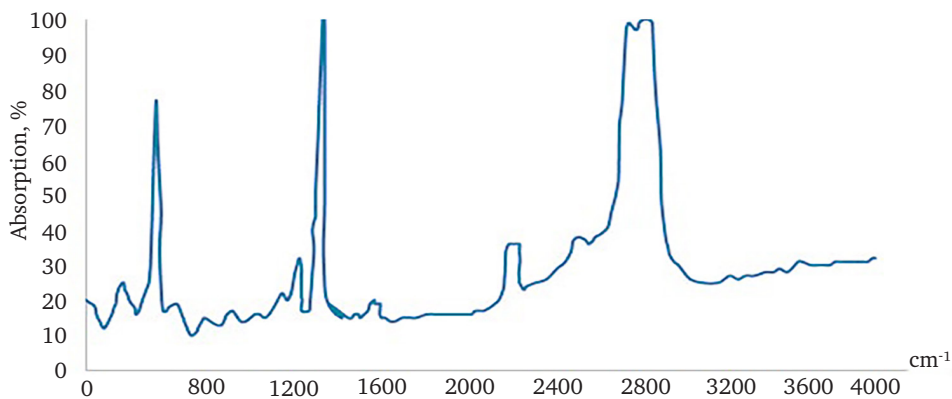

Figure 7. Change in the IR spectra of an LDPE film with a modifying additive of phthalimide at 0.05 wt% after electrical ageing under the action of discharges in air

Note: $U = 7 \text{ kV}$, $t = 5 \text{ hours}$

Source: compiled by the authors

As can be seen from Figures 6 and 7 after the electrical ageing of LDPE films, a new absorption band is observed in the IR spectra and the bands 1720-1710 ($\text{C} = \text{O}$ groups) are the most pronounced. However, judging by the change in the intensity of the absorption band of the $\text{C} = \text{O}$ groups of LDPE films all other things being equal, the amount of phthalimide applied to LDPE, the intensity of the absorption bands of the terminal carbonyl groups decreases significantly.

Since the intensity of absorption in the IR spectrum in the first approximation is proportional to the number of corresponding groups in the sample, it can be concluded that the used modifier, due to the presence of highly dispersed particles, acts as an

active structure former, homogenizing the LDPE structure, and thereby slows down the course of oxidative processes. H. Boughrara *et al.* [19] explored an easy and effective method to enhance the compatibility of blends containing low-density polyethylene (LDPE) and poly(ϵ -caprolactone) (PCL). The research investigated the use of specific compatibilizers or additives to promote better mixing and interaction between LDPE and PCL, ultimately improving the overall performance of the blend. Enhanced compatibilization of LDPE/PCL blends can form materials with tailored properties, making them suitable for various applications, including packaging, biomedical materials, and sustainable polymer composites. R.P. D'Amelia *et al.* [20], using

Fourier Transform Infrared Spectroscopy (FTIR), studied the chemical interactions and structural characteristics of these polymer copolymers and blends. FTIR allows for the detection and analysis of functional groups present in the samples, as well as the determination of the degree of polymerization. Alongside FTIR, elemental analysis is employed to accurately determine the composition of the samples, including the content of hydrogen, carbon, and other elements in the polymer materials [21]. This is crucial for the quantitative assessment of copolymers and blends. This research has significant industrial applications, where the precise composition and structural characteristics of polymer materials impact their properties and quality [22].

Thus, in this case, the rate of decrease in the electrical strength of the LDPE film during its ageing with the introduction of a small number of additives also indicates the formation of densely packed structures due to fine spherulite organization, which prevents oxygen diffusion and the development of ionization processes during electrical destruction, which is in good agreement with the change in IR spectra.

Conclusions

The composition and amount of a low molecular weight organic additive modifying the electrophysical properties of LDPE 10803-020 have been determined. The developed modification of LDPE is distinguished by a significantly small number of additives used and their technological compatibility. A systematic study of the electrophysical properties of the LDPE film and its developed modifications has been carried out. Composites with the addition of 0.05 wt% phthalimide significantly increase the electrical strength, and volumetric electrical resistance and reduce the dielectric loss tangent, i.e., there is a noticeable correlation between these characteristics.

The structural changes in LDPE and its modifications were studied by IR spectroscopy, which was used to establish the contribution of the modifying organic additive phthalimide to the stability of the electrophysical properties of LDPE during its ionization ageing under the action of electric discharges. It is shown that the introduction of the modifiers used in the indicated amount into LDPE contributes to a noticeable decrease in the intensity of the formation

of $c = 0$ groups (1720 cm^{-1}), which is a measure of the oxidative degradation of polymer targets. The experimental facts confirm the assumption that the proposed phthalimide modifiers in a small amount (0.05 wt%) are artificial nuclei of structure formation for LDPE. Consequently, a more ordered structure of LDPE, containing the optimal amount of modifier, will hinder the diffusion of atmospheric oxygen polymers even during their ionization ageing.

A qualitative assessment of the change in the LDPE film with the introduction of small additives is the determination of the morphology of supramolecular formations using electron scanning microscopy and X-ray diffraction. The data obtained allow us to approach the explanation of experimental results from a scientific point of view, establish the relationship between the structure and properties of polymer products, and conduct a targeted search for the most optimal alloying additives that can improve the physical, mechanical, and technological properties of the polymer. In addition, the dielectric and mechanical antistatic characteristics of the specified polymer composition were studied before and after electrical, UV and gamma irradiation.

Further investigations could delve deeper into the underlying mechanisms of how phthalimide interacts with high-pressure polyethylene during electrical ageing. This might involve advanced analytical techniques and computational modelling to provide a more comprehensive understanding of the processes involved. Research could focus on optimizing the concentration of phthalimide to achieve the most effective mitigation of electrical ageing. This could involve a systematic exploration of various concentrations to find the optimal balance between performance improvement and material cost. Extending the duration of electrical ageing experiments could help assess the long-term stability and effectiveness of phthalimide as an ageing inhibitor. This would be valuable for applications where extended lifetimes are crucial, such as high-voltage insulation materials.

Acknowledgements

None.

Conflict of Interest

None.

References

- [1] Godzhaev EM, Kerimov FSh, Alekperov AM. [Influence of unirradiation on the electrical properties of a high-density polyethylene film modified with phthalimide additive](#). *Azerb J. Phys.* 2022;2022:38–40.
- [2] Sadygova AR, Abbasov II, Safiev ES, Asilbeyli PB, Alekperov VA. Influence of nanoclay microadditives on the molecular processes and kinetics of electrical and mechanical destruction of polyethylene. *Nanosyst Nanomater Nanotechnol Nanosyst.* 2019;17(1):155–65. [DOI: 10.15407/nnn.17.01.155](#).
- [3] Khadiyeva AA, Asilbeyli PB, Sadygova AR, Ismailov IM. [Molecular processes in electric destruction of nanocomposites on the basis of PE and nanoclay after external factors](#). 2022. Baku: Institute of Physics; P. 84–8.

- [4] Chiong H, Daliparthi SPR, Deshpande HS, Guggenheim TL, Khouri FF, Kumar MS, Navarro De Castro MA, Odle RR, Sivakumar P, Dhumal SS, Sreeramagiri SK, Smith BA. Manufacturing processes of bis (phthalimide) s and polyetherimides, and bis (phthalimide) s and polyetherimides formed therefrom. Publication of ES2672580T3. June 15, 2018. Available from: <https://patents.google.com/patent/ES2672580T3/en>.
- [5] Cubric IS, Cubric G, Križman IK Kovacevi M. Evaluation of changes in polymer material properties due to aging in different environments. *Polymers*. 2022;14:1682. DOI: [10.3390/polym14091682](https://doi.org/10.3390/polym14091682).
- [6] Almond J, Sugumaar P, Wenzel MN, Hill G, Wallis C. Determination of the carbonyl index of polyethylene and polypropylene using specified area under band methodology with ATR-FTIR spectroscopy. *e-Polym*. 2020;20:369-381. DOI: [10.1515/epoly-2020-0041](https://doi.org/10.1515/epoly-2020-0041).
- [7] Nečas D, Klapetek P. Synthetic data in quantitative scanning probe microscopy. *Nanomater*. 2021;11(7):1746. DOI: [10.3390/nano11071746](https://doi.org/10.3390/nano11071746).
- [8] Greene JP. 12-Polymer composites. *Automot Plast Compos. Materials and Processing. Plastics Design Library*. 2021;2021:191–222. DOI: [10.1016/B978-0-12-818008-2.00007-6](https://doi.org/10.1016/B978-0-12-818008-2.00007-6).
- [9] Cundiff KN, Madi Y, Benzerga AA. Photo-oxidation of semicrystalline polymers: Damage nucleation versus growth. *Polym*. 2020;188:122090. DOI: [10.1016/j.polymer.2019.122090](https://doi.org/10.1016/j.polymer.2019.122090).
- [10] Rodriguez AK, Mansoor B, Ayoub G, Colin X, Benzerga AA. Effect of UV-aging on the mechanical and fracture behavior of low density polyethylene. *Polym Degrad Stab*. 2020;180:109185. DOI: [10.1016/j.polymdegradstab.2020.109185](https://doi.org/10.1016/j.polymdegradstab.2020.109185).
- [11] Uflyand IE, Drozan EG, Burlakova VE, Kydraliev KA, Shershneva IN, Dzhardimalieva GI. Testing the mechanical and tribological properties of new metal-polymer nanocomposite materials based on linear low-density polyethylene and Al₆₅Cu₂₂Fe₁₃ quasicrystals. *Polym Test*. 2019;74:178–86. DOI: [10.1016/j.polymertesting.2019.01.004](https://doi.org/10.1016/j.polymertesting.2019.01.004).
- [12] Nuriev MA, Magerramov AM, Shukyurova AA. Electrical conductivity of nanocomposites based on low-density polyethylene and Cu₂S nanoparticles. *Surf Eng Appl Electrochem*. 2018;54(1):32–7. DOI: [10.3103/S1068375518010118](https://doi.org/10.3103/S1068375518010118).
- [13] Kumar V, Gulati K, Lal S, Arora S. Effect of gamma irradiation on tensile and thermal properties of poplar wood flour-linear low-density polyethylene composites. *Radiat Phys Chem*. 2020;174:108922. DOI: [10.1016/j.radphyschem.2020.108922](https://doi.org/10.1016/j.radphyschem.2020.108922).
- [14] Zeynalov Sh, Garacayev B, Khalilov S, Kerimov F, Alekperov A. [Study of the mechanical durability of a high-pressure polyethylene film and its composition at various temperatures](#). *Norw J Dev Int Sci*. 2022;(86):53-56.
- [15] Garibli AA, Melikova SZ, Ramazanov MA, Garibov AA. [The study of the interaction of components in the composite nanosilicon + polypropylene Fourier Transform Infrared Spectroscopy and X-Ray diffraction methods](#). *Azerb J Phys*. 2018;24(4):38-47.
- [16] Kim SH, Yun UH, Kim JG. Low-density polyethylene degradation and energy yield using dielectric barrier discharge under various electrical conditions. *Energ*. 2023;16(5):2403. DOI: [10.3390/en16052403](https://doi.org/10.3390/en16052403).
- [17] Qiao Z, Wu W, Wang Z, Zhang L, Zhou Y. Space charge behavior of thermally aged polyethylene insulation of track cables. *Polym*. 2022;14(11):2162. DOI: [10.3390/polym14112162](https://doi.org/10.3390/polym14112162).
- [18] Smith BC. The infrared spectra of Polymers II: Polyethylene. *Spectrosc*. 2021;36(9):24–9. DOI: [10.56530/spectroscopy.xp7081p7](https://doi.org/10.56530/spectroscopy.xp7081p7).
- [19] Boughrara H, Djellali S, Haddaoui N, Staelens JN, Supiot P, Maschke U. A facile route to improve compatibilization of low-density polyethylene/poly(ϵ -caprolactone) blends. *Polym Degrad Stab*. 2022;204:110111. DOI: [10.1016/j.polymdegradstab.2022.110111](https://doi.org/10.1016/j.polymdegradstab.2022.110111).
- [20] D'Amelia RP, Huang L, Mancuso J. [Quantitative Analysis of polyvinyl alcohol-polyethylene \(PVOH-PE\) copolymers and polyvinyl pyrrolidone-polyvinyl acetate \(PVP-PVAc\) copolymers and blends using Fourier Transform infrared spectroscopy and elemental analysis](#). *World J Chem Educ*. 2019;7(1):1–11.
- [21] Panov V. The scientific process of two interferometers (optical) development and the mitigation of external influence. *Sci Herald Uzhhorod Univ Ser Phys*. 2023;(53):19–30. DOI: [10.54919/physics/53.2023.19](https://doi.org/10.54919/physics/53.2023.19).
- [22] Pylypchynets I. Optimal scheme for stimulating photofission of shielded nuclear materials on the Microtron M-30: A combination of theoretical and experimental studies. *Sci Herald Uzhhorod Univ Ser Phys*. 2022;52:16–26. DOI: [10.54919/2415-8038.2022.52.16-26](https://doi.org/10.54919/2415-8038.2022.52.16-26).

Вплив фталіміду на процес електричного старіння поліетилену високого тиску

Шукаят Аман Зейналов

Кандидат фізико-математичних наук, доцент
Азербайджанський технічний університет
AZ 1073, проспект Г. Джавіда, 25, м. Баку, Азербайджан
<https://orcid.org/0000-0002-0040-6057>

Фархад Шаміль Керімов

Кандидат фізико-математичних наук, доцент
Азербайджанський технічний університет
AZ 1073, проспект Г. Джавіда, 25, м. Баку, Азербайджан
<https://orcid.org/0009-0005-8006-5481>

Севінь Іттіфак Сафарова

Кандидат фізико-математичних наук, доцент
Азербайджанський технічний університет
AZ 1073, проспект Г. Джавіда, 25, м. Баку, Азербайджан
<https://orcid.org/0009-0003-5928-1177>

Саяра Гейдар Садигова

Кандидат фізико-математичних наук, доцент
Азербайджанський технічний університет
AZ 1073, проспект Г. Джавіда, 25, м. Баку, Азербайджан
<https://orcid.org/0009-0003-0492-4825>

Тахір Паша Мусаєв

Кандидат фізико-математичних наук, доцент
Азербайджанський технічний університет
AZ 1073, проспект Г. Джавіда, 25, м. Баку, Азербайджан
<https://orcid.org/0009-0001-6719-874X>

Анотація

Актуальність. Використання поліолеодинів без додаткових методів обробки, а саме підвищення їх електрофізичних характеристик, є актуальною сучасною вимогою експлуатації. Для цього необхідно використовувати механізм іонізаційного старіння, де роль модифікуючої добавки в цьому повинна бути з'ясована методом інфрачервоної спектроскопії в поліетилені високого тиску.

Мета. Метою роботи було вивчення впливу низькомолекулярних органічних добавок фталіміду на молекулярно-структурні зміни полімерів, що відбуваються під дією зовнішнього середовища.

Методологія. Вплив електричних розрядів на полімерні діелектрики проводили в дослідній комірці несиметричного типу. Відповідно до процедури на цю пластину щільно натягували досліджувану полімерну плівку до і після попереднього розтягування. Для створення повітряного зазору постійної товщини між верхнім електродом і полімерною плівкою по краях розташовували скляні прокладки товщиною 1,5 мм.

Результати. Досліджено електричну міцність (термін служби) поліетилену високого тиску (LDPE) та його оптимальну модифікацію до та після електричного старіння. На підставі експериментальних даних встановлено, що вміст 0,05 мас. % LDPE, його електрична міцність досягає максимального значення в порівнянні як з вихідним LDPE, так і з LDPE при інших вмістах добавок. Показано, що введення 0,05 мас. % фталіміду в поліетилен високого тиску сприяє помітному зниженню інтенсивності утворення $C = O$ груп, що є мірою окиснювальної деструкції полімерних ланцюгів.

Висновки. Визначено оптимальний склад фталімідів та вивчено їх електрофізичні властивості. Встановлено, що композити з добавками 0,05 мас.% фталіміду значно покращують електрофізичні властивості LDPE.

Ключові слова: інфрачервоний спектр; час життя; полімерні ланцюги; електрофізичні властивості; електрична довговічність